

BAC2000_{ind}

DESCRIPTION

ASI is a leader in the supply of industrial grade motor controllers with roots in electric vehicle technology dating back over 20 years.

The BAC2000_{ind} is a high power density electric vehicle controller utilizes the latest in field oriented control to ensure smooth, quiet brushless DC motor operation and efficient vehicle operation.

SMOOTH

- throttle control is responsive and jerk free
- excellent driver experience

SMALL

- compact footprint provides locational flexibility

SMART

- advanced field oriented control for maximum efficiency
- numerous programmable features and adjustments
- based on BAC product architecture
- protective and diagnostic features

SILENT

- Sinusoidal wave forms eliminate motor buzzing

CONNECTED

- CAN network interface supports either standalone or slave module operation in vehicle applications requiring multiple drive or accessory motors
- Programmable update rates
- Real time controller status, battery voltage, motor currents and motor or controller temperature ensures safe vehicle operation
- Programmable through an optional display or PC connection
- LED status indicator makes trouble shooting a breeze

RUGGED

- Automotive quality Molex™ connectors, and rugged ABS case
- Current and thermal limiting protects motor, controller and I/O



KEY FEATURES

- 75A continuous current
- CAN communications network
- Sensorless or sensored commutation modes
- Programmable (update rate and content) controller status available over CAN network
- POST protected MOSFET bridge
- Programmable regenerative braking
- Dual programmable low side digital outputs (2A drive capability)
- 6x digital inputs (including 1x optically isolated input)
- 3x analog inputs
- Networked or standalone configuration option
- Designed to IP65
- Controller status LED
- Evaluation kits available

BATTERY VOLTAGE

- 30 to 60V DC Input

OUTPUT CAPABILITY

- Up to 120A peak

APPLICATIONS

- Electric tractors
- Snow blowers
- Small vehicles
- Electric scooters

Distributed By:

FEATURES AND BENEFITS

Control

- Fully programmable via optional vehicle display or ASI PC software package
- Sinusoidal field oriented control for exceptionally smooth operation and increased motor efficiency
- 3-phase 12.5KHz PWM for 95% efficient motor control
- Regenerative braking harnesses excess energy to extend the battery charge

Flexibility

- Programmable motor temperature fold back feature increases motor life span by reducing temperature related stress and magnet degradation
- Programmable battery voltage over/under fault levels enhance controller and motor longevity
- Programmable motor/battery current fault levels enhance controller and motor longevity
- Programmable controller temperature fault enhances controller and motor longevity
- Programmable PWM switched low side digital outputs will drive coils of varying voltages up to 60V
- Programmable to match the unique characteristics of the user's BLDC motor

Communications

- Networkable as a slave module with CAN address settable through the vehicle harness
- Isolated CAN network option available for use in high noise vehicle environments
- 1 M bit CAN network rate coupled with four predetermined status packets that include battery voltage, motor current, etc. (see data sheet for specifics) and programmable update rates provide real time vehicle operation feed back
- LED display of fault codes for easy trouble shooting and fault diagnosis

Safety

- Digital inputs that can be connected directly to the battery system make BAC2000_{ind} ideally suited for small vehicle applications involving safety logic (belly, seat, throttle and brake switches)
- Enclosure designed to make the drive suitable for use in the most demanding vehicle environments
- Single optically isolated digital input (2500Vrms isolation) allows use in electrically noisy vehicle environments and protects BAC2000_{ind} from high voltage transients occurring elsewhere in the vehicle system
- 0 to 5V analog brake and throttle inputs with programmable dead band and broken wire detection make BAC2000_{ind} easily configurable to the user's application requirements
- Programmable regenerative braking facilitates smooth, accurate, and quick changes of direction as well as extending vehicle run time
- Short circuit and motor phase integrity protection protects the 3 phase MOSFET bridge by testing motor drive componentry prior to application of current to the motor

SPECIFICATIONS

Controller Performance

Feature	Range	Units
Rated Voltage	30 to 60	Volts
Rated Output Power	150 to 2000	Watts
Motor Control Method	Field Oriented Control (FOC)	
Safety	EN 15194 compliant	
Standby Power Consumption	< 3	Watts
Speed Limit	User programmable and limited by the motor	Km/h
Operating Modes	Speed, Torque and Combined	

System Protection Features

Protection	Description
Over/Under Voltage	If the battery voltages above/below the user programmable thresholds, the bridge is disabled
Motor Over current	If the instantaneous or averaged current above the user programmable thresholds, the bridge is disabled
Bridge On/Off Test	Tests the MOSFET bridge is operating properly prior to providing output power to motor
Motor Temperature	User programmable protection using either external thermistor mounted on the motor windings or motor nameplate based I ² T thermal model
Bridge Temperature	If the MOSFET tab temperature exceeds the factory programmed limit, the motor phase current will be folded back to protect the controller
Throttle/Brake Outside Range	If measured voltage is outside the user programmed throttle voltage + throttle fault range, the bridge is disabled
Internal Error	If the processor has detected an error in flash memory or the main clock signal, the bridge is disabled
Power On Self Test (POST)	If the phase current sensors have not calibrated properly, the bridge is disabled

Additional Controller Features

Feature	Description
Command Sensor Support	Resistive, and Hall based throttles are supported
Sinusoidal Sensorless Commutation	For select applications, BLDC motor's can be commutated without the use of Hall sensors
Regenerative Braking	Excess energy generated during braking events can be used to extend the battery charge

Communications

Feature	Description
Programming and Configuration	Controller can be programmed/debugged using ASI's Bac Door™ PC configuration software and a USB port
Status Display	Controller status/fault codes flashed on externally visible LED
Network	Proprietary ASI object dictionary over a variable 1 Mbit CAN network
Communication Hardware Protocols	RS-232 and CAN bus are supported

DIMENSIONS

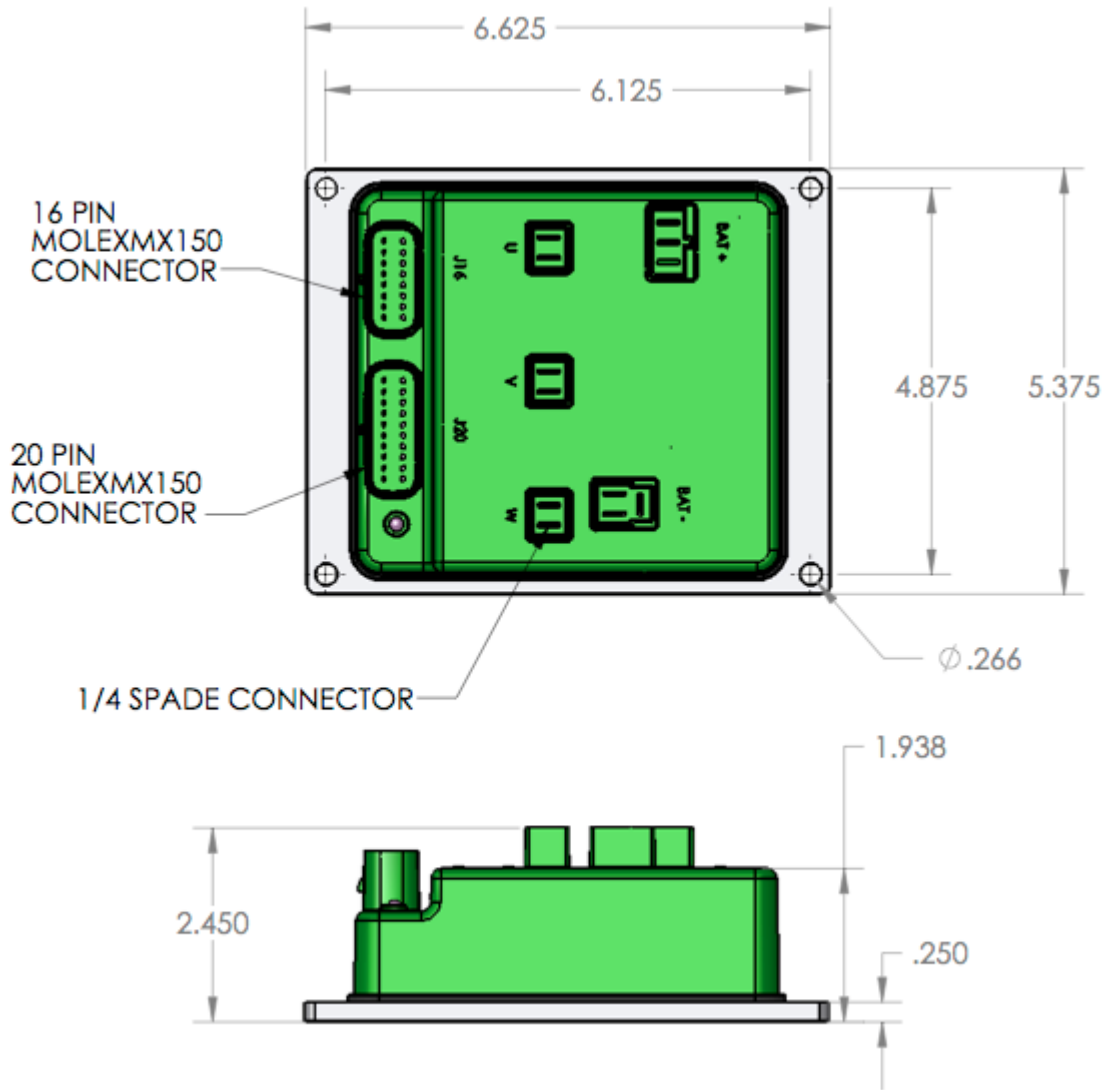

CONNECTOR SPECIFICATIONS

Part	Manufacturer Part Number
16 pin, Molex female, MX150 series	0334721606
20 pin, Molex female, MX150 series	0334722006
Contact connector, Molex female pin	0330122001
Battery & motor phase terminals, 10-12AWG female spade, 0.250", insulated	Yellow female spade, "FASTON", various manufacturers

TYPICAL WIRING DIAGRAM

BAC 2000 *ind* BLDC Controller
Wiring Diagram Rev 1.00

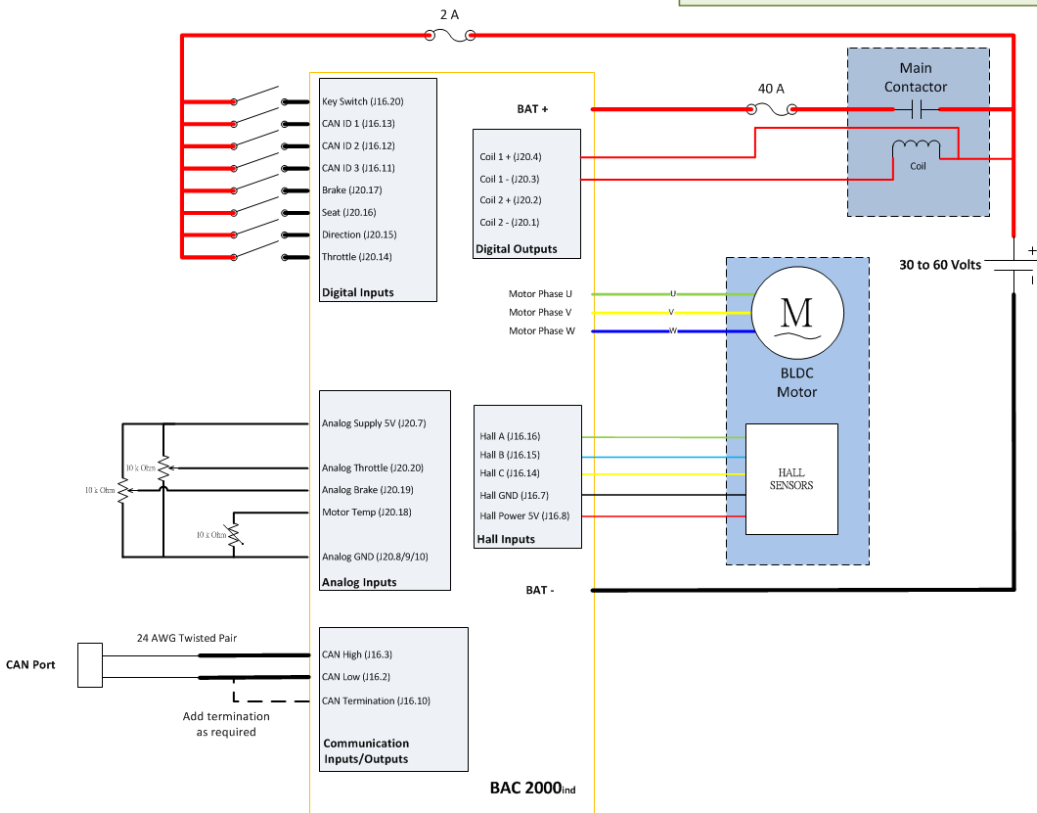

Accelerated Systems Inc.
575 Kumpf Dr.
Waterloo Ontario N2V 1K3 Canada
Phone: 1-519-342-2507
Fax: 1-519-342-2508
www.accelerated-systems.com
info@accelerated-systems.com